

GSM Audio Player

Application Note

GSM/GPRS Module Series

Rev. GSM_Audio_Player_Application_Note_V3.2

Date: 2015-05-20



Our aim is to provide customers with timely and comprehensive service. For any assistance, please contact our company headquarters:

Quectel Wireless Solutions Co., Ltd.

Office 501, Building 13, No.99, Tianzhou Road, Shanghai, China, 200233

Tel: +86 21 5108 6236

Mail: info@quectel.com

Or our local office, for more information, please visit:

<http://www.quectel.com/support/salesupport.aspx>

For technical support, to report documentation errors, please visit:

<http://www.quectel.com/support/techsupport.aspx>

Or Email: Support@quectel.com

GENERAL NOTES

QUECTEL OFFERS THIS INFORMATION AS A SERVICE TO ITS CUSTOMERS. THE INFORMATION PROVIDED IS BASED UPON CUSTOMERS' REQUIREMENTS. QUECTEL MAKES EVERY EFFORT TO ENSURE THE QUALITY OF THE INFORMATION IT MAKES AVAILABLE. QUECTEL DOES NOT MAKE ANY WARRANTY AS TO THE INFORMATION CONTAINED HEREIN, AND DOES NOT ACCEPT ANY LIABILITY FOR ANY INJURY, LOSS OR DAMAGE OF ANY KIND INCURRED BY USE OF OR RELIANCE UPON THE INFORMATION. THE INFORMATION SUPPLIED HEREIN IS SUBJECT TO CHANGE WITHOUT PRIOR NOTICE.

COPYRIGHT

THIS INFORMATION CONTAINED HERE IS PROPRIETARY TECHNICAL INFORMATION OF QUECTEL CO., LTD. TRANSMITTABLE, REPRODUCTION, DISSEMINATION AND EDITING OF THIS DOCUMENT AS WELL AS UTILIZATION OF THIS CONTENTS ARE FORBIDDEN WITHOUT PERMISSION. OFFENDERS WILL BE HELD LIABLE FOR PAYMENT OF DAMAGES. ALL RIGHTS ARE RESERVED IN THE EVENT OF A PATENT GRANT OR REGISTRATION OF A UTILITY MODEL OR DESIGN.

Copyright © Quectel Wireless Solutions Co., Ltd. 2015. All rights reserved.

About the Document

History

Revision	Date	Author	Description
3.0	2013-02-19	Thomas ZHANG	Initial
3.1	2013-04-18	Thomas ZHANG	<ol style="list-style-type: none">1. Modified the sampling rate of audio recording format in Table 2.2. Modified Figure 1: Audio Playback Overview3. Renamed "Receiver" as "Normal Audio Channel".4. Renamed "Earphone" as "Headset".5. Modified AT Commands: AT+QPLAYRES/AT+QPSND.
3.2	2015-05-20	Thomas ZHANG	Added applicable modules

Contents

About the Document	2
Contents	3
Table Index	4
1 Introduction	5
2 Overview	6
3 Audio Recording	7
3.1. Record from Microphone	7
3.2. Record from Voice Call	7
3.3. Supported Recording Format	7
4 Audio Playback	8
4.1. Source of Playback	9
4.1.1. Playback from File System	9
4.1.2. Playback from Stream (.bin).....	9
4.1.3. Playback from Stream (UART Input).....	9
4.2. Type of Playback.....	9
4.2.1. Playback in Idle State.....	10
4.2.2. Playback in Voice Call State	10
4.3. Supported Audio Formats	10
5 Related AT Command Description	11
5.1. AT Command Syntax	11
5.2. Description of AT Command	11
5.2.1. AT+QAUDRD Record Media File	11
5.2.2. AT+QAUDPLAY Play Media File	13
5.2.3. AT+QAUDSTOP Stop Playing Media File	14
5.2.4. AT+QPLAYRES Play Audio Stream from Resource Bin	15
5.2.5. AT+QSTOPRES Manually Stop the Audio Resource Playing.....	16
5.2.6. AT+QPRESBG Playback Audio from Resource Bin to the Remote in Call	16
5.2.7. AT+QPSND Play Audio File and Send it to the Remote in Call	18
5.2.8. AT+QPCMD Play PCM Stream from UART to the Remote in Call	19
5.2.9. AT+QMEDVL Set/Get Media Volume Gain	21
6 Appendix A Reference	22
7 Appendix B Error Codes	23
8 Appendix C Audio Resource Generator	24
8.1. Overview	24
8.1.1. Advantages	24
8.1.2. Procedure.....	24
8.2. Make and Download Bin File	25
8.2.1. Make Bin File.....	25
8.2.2. Download Audio Bin File to Module	28

Table Index

TABLE 1: SUPPORTED MODULES	6
TABLE 2: RECORDING FORMAT	7
TABLE 3: AT COMMANDS MATRIX.....	9
TABLE 4: SUPPORTED AUDIO FORMATS	10
TABLE 5: +QAUDRIND CODE	13
TABLE 6: +QAUDPIND CODE	14
TABLE 7: RELATED DOCUMENTS	22
TABLE 8: TERMS AND ABBREVIATIONS	22
TABLE 9: DESCRIPTION OF DIFFERENT CODING SCHEMES.....	23

Quectel
Confidential

1 Introduction

This document describes the functions of audio playback and audio recording of Quectel modules. The revolved AT commands are listed in this document.

This document is applicable to Quectel M10, M66, M95 and M85 modules.

Quectel
Confidential

2 Overview

For Quectel modules with audio function, most of them have two analog audio channels at least.

Audio could be recorded from microphone or uplink / downlink speech, and stored, in the form of files, into memory, such as flash and SD card. These recorded audio files can also be played back with modules' DAC and DSP. Besides, playback of audio stream stored in binary or input from UART is supported as well.

The functions related to file operation, such as recording, audio file playback, are only available on Quectel modules with UFS (user file storage) function. The UFS function is mostly provided in the module with enough flash memory, 32Mbit at least.

AT+QPLAYRES and AT+QPRESBG are supported in module with 64Mbit and above flash. AT+QAUDRD, AT+QAUDPLAY, AT+QAUDSTOP and AT+QPSND are supported in module with 32Mbit and above flash. AT+QPCMD is supported in module with flash smaller than 32Mbit.

The following table lists the detailed supported modules.

Table 1: Supported Modules

AT Commands	M10	M66	M95	M85
AT+QAUDRD	YES	YES	YES	YES
AT+QAUDPLAY	NO	YES	YES	YES
AT+QAUDSTOP	NO	YES	YES	YES
AT+QPLAYRES	NO	YES	NO	YES
AT+QSTOPRES	NO	YES	NO	YES
AT+QPRESBG	NO	YES	NO	YES
AT+QPSND	NO	YES	NO	YES
AT+QPCMD	YES	YES	YES	YES
AT+QMEDVL	NO	YES	YES	YES

These functions will be described in the next few chapters.

3 Audio Recording

3.1. Record from Microphone

Use the AT+QAUDRD (details in section 5.2.1) can record the sound from microphone. AT+QAUDCH can select which microphone channel to be used. Several media formats are supported, such as WAV_PCM16, WAV_ALAW, WAV_ULAW, WAV_ADPCM and AMR. Refer to *Table 2: Recording Format*. See the AT commands description for more information.

3.2. Record from Voice Call

Downlink and uplink speech could be recorded during voice call. Use the same AT+QAUDRD command, just after call is established.

3.3. Supported Recording Format

Table 2: Recording Format

Format	Encoding	Sampling Rate	Sampling Resolution	Encoding Digit	Encode Speed	File Size
3	AMR	8 KHz	13 bit			40 KB/min
13	WAV_PCM16	8 KHz	16 bit	16 bit	128 kbps	960 KB/min
14	WAV_ALAW	8 KHz	16 bit	8 bit	64 kbps	480 KB/min
15	WAV_ULAW	8 KHz	16 bit	8 bit	64 kbps	480 KB/min
16	WAV_ADPCM	8 KHz	16 bit	4 bit	32 kbps	240 KB/min

4 Audio Playback

Two aspects will be described here. One is the source of the playback. Audio can be played back from the file system or from binary stream or even from UART. The other is the type of the playback. Audio can be playback in the voice call state and idle state. Different commands should be used for different combination of these two aspects. See the table below. The formats supported for each command is different either. See Chapter 4.3.

See the following figure and table to get an overview of the audio playback.

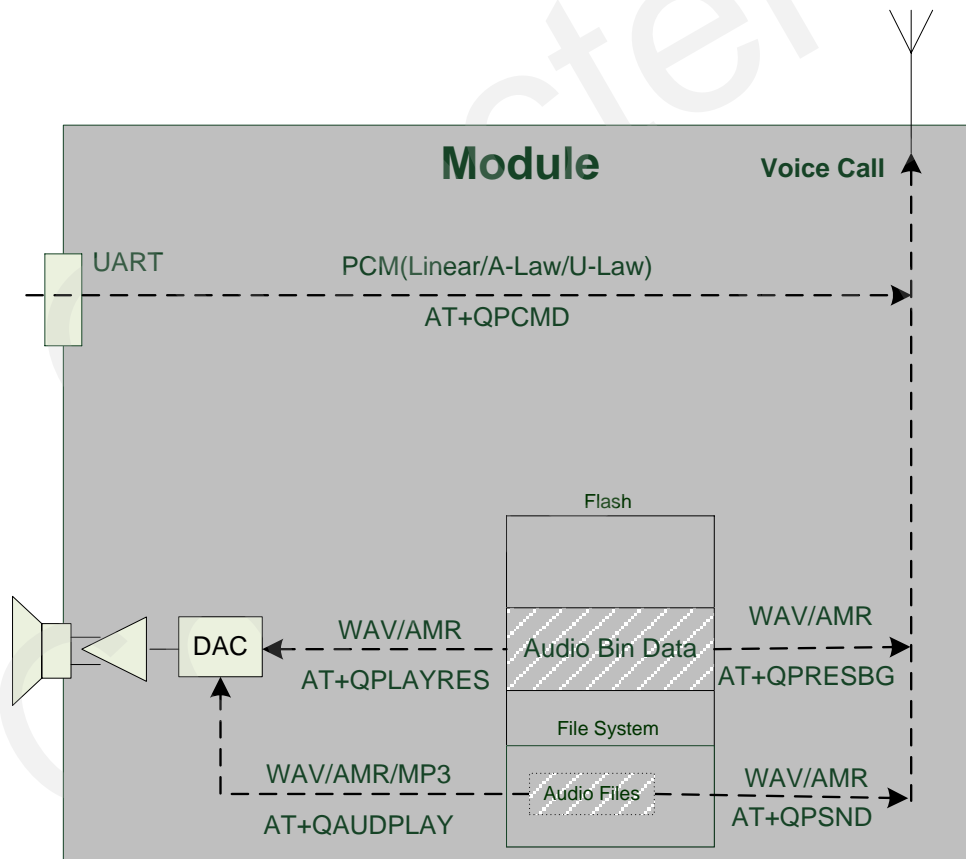

Figure 1: Audio Playback Overview

Table 3: AT Commands Matrix

	File system	Bin	UART
Idle	AT+QAUDPLAY	AT+QPLAYRES	AT+QPCMD
Voice Call	AT+QPSND	AT+QPRESBG	AT+QPCMD

4.1. Source of Playback

Audio data (digital form) to be played back can come from several sources, files stored in file system, data binary (.bin) stored in the flash, and PCM stream input from UART.

4.1.1. Playback from File System

Audio files stored in module's file system could be played back, either in flash or in memory card. In idle state (no call), AT+QAUDPLAY (section 5.2.2) is used to play the audio files. During voice call, AT+QPSND (section 5.2.7) is used to play the audio files to the other side of the call.

4.1.2. Playback from Stream (.bin)

Audio data could be packed into a binary file (.bin) and downloaded into module's flash memory, just like module's firmware. The data is structured into the binary. The PC side tool is provided to generate such bin for production line. See appendix C (Chapter 8) for the detailed usage of audio resource bin generator.

In idle state, AT+QPLAYRES (section 5.2.4) is used to play such audio resource. During voice call, AT+QPRESBG (section 5.2.6) is used to play such audio resource to the other side of the call.

4.1.3. Playback from Stream (UART Input)

PCM stream input from UART can also be played back. AT+QPCMD (section 5.2.8) is used in this scenario. It should be noticed that only 8 KHz sampling rate is supported.

4.2. Type of Playback

The type mentioned here is to play in idle or voice call state. Different type supports the different audio playback format. In general, playback in idle state can support more formats than in voice call state.

4.2.1. Playback in Idle State

Idle state means no call exists. Sound will output to local speakers. AT+QAUDPLAY (section 5.2.2) and AT+QPLAYRES (section 5.2.4) belong to such category.

4.2.2. Playback in Voice Call State

The played sound will be mixed into the downlink and uplink speech stream and send to the far end of voice call. AT+QPSND (section 5.2.7), AT+QPRESBG (section 5.2.6) and AT+QPCMD (section 5.2.8) belong to such category.

4.3. Supported Audio Formats

The table below shows the formats supported in each command.

Table 4: Supported Audio Formats

Commands	Supported Formats
AT+QAUDPLAY	WAV (Linear PCM, A-Law, U-Law, ADPCM), AMR, MP3
AT+QPSND	8 KHz sampling rate WAV, AMR
AT+QPLAYRES	WAV (Linear PCM, A-Law, U-Law, ADPCM), AMR
AT+QPRESBG	8 KHz sampling rate WAV (Linear PCM, A-Law, U-Law, ADPCM), AMR
AT+QPCMD	8 KHz sampling rate: raw data of linear PCM, A-Law and U-Law

5 Related AT Command Description

5.1. AT Command Syntax

Test Command	AT+<x>=?	This command returns the list of parameters and value ranges set by the corresponding Write Command or internal processes.
Read Command	AT+<x>?	This command returns the currently set value of the parameter or parameters.
Write Command	AT+<x>=<...>	This command sets the user-definable parameter values.
Execution Command	AT+<x>	This command reads non-variable parameters affected by internal processes in the GSM engine

5.2. Description of AT Command

5.2.1. AT+QAUDRD Record Media File

Record the uplink and downlink speech during voice call or record sound from local microphone in idle state and save it to files.

AT+QAUDRD Record Media File	
Test Command AT+QAUDRD=?	Response +QAUDRD: (list of supported <control>s),"filename"[(list of supported <format>s)] OK
Read Command AT+QAUDRD?	Response +QAUDRD: <state> OK
Write Command AT+QAUDRD=<control>["filename"],["<format>"]	Response OK
Reference	

Parameter

<state>	Recording state
	0 Module is not in recording
	1 Module is in recording
"filename"	Name of the file to record, refer to Note 1
<format>	Format of the file, refer to Note 2
	3 AMR
	13 WAV_PCM16
	14 WAV_ALAW
	15 WAV_ULAW
	16 WAV_ADPCM
<control>	Start to record or stop the recording
	0 Stop the recording
	1 Start to record

NOTES

- "filename" includes file path, file name and file suffix. File path can be UFS, RAM, SD root directory and SD subdirectory. Corresponding examples, "Example.wav", "RAM:Example.wav", "SD:Example.wav" and "SD:Directory\\Example.wav". File suffix can be "wav" or "amr" when the <format> is omitted. For "amr" suffix, file is stored in AMR coding format. For "wav" suffix, file is stored in WAV_ADPCM coding format in voice call state, and stored in WAV_PCM16 coding format in idle state.
- When the file suffix is "amr", the format can only be "3" (AMR). When the file suffix is "wav", the format can be "13" (WAV_PCM16), "14" (WAV_ALAW), "15" (WAV_ULAW), and "16" (WAV_ADPCM). For other suffixes, parameter <format> must be provided. Please refer to Table 2: Recording Format.
- If the recording file's name and format is same with an existed file. Recording data will be appended to the end of the file.
- Record media file to SD subdirectory, you need to create the subdirectory manually first.
- Audio channel is decided by AT command: AT+QAUDCH
- The recording would be forced to quit in the following cases.
 - Start to record when module is on idle. Make a call or answer a call, the recording would be forced to quit.
 - Start to record when module is on a call. The recording would be forced to quit when the call is hanged up.

When the recording is forced to quit, URC **+QAUDRIND: 0,<code>** would be output through UART. Refer to *Table 5: +QAUDRIND Code*.
- Gain of the recording cannot be adjusted by AT command.

Table 5: +QAUDRIND Code

<code>	Meaning
0	Reserved
1	Unknown error
3	Disk is full
6	Interrupted by other audio task
10	Disk not found

5.2.2. AT+QAUDPLAY Play Media File

Play back the audio files in idle mode and output to speakers.

AT+QAUDPLAY Play Media File

Test Command AT+QAUDPLAY=?	Response +QAUDPLAY: "filename",(list of supported <repeat>s),(list of supported <volume>s)[,(list of supported <channel>s)]
	OK
Write Command AT+QAUDPLAY="filename",<repeat>,<volume>[,<channel>]	Response OK
Reference	

Parameter

"filename"	Name of the file to play, includes file path, file name and file suffix. File suffix can be AMR,WAV or MP3
<repeat>	Whether to play media file repeatedly 0 Play only one time 1 Play repeatedly
<volume>	Volume level to play media file Range: 0-100
<channel>	Channel to play media file 0 Normal audio channel 1 Headset

2 Loud Speaker

NOTES

1. If the <channel> parameter is omitted, channel is decided by AT command: AT+QAUDCH.
2. When the playing is finished or interrupted by other audio tasks, URC **+QAUDPIND: 0,<code>** would be output through UART. Refer to *Table 6: +QAUDPIND code*.

Table 6: +QAUDPIND code

<code>	Meaning
5	Playing is finished
6	Interrupted by other audio tasks
9	Unknown error

5.2.3. AT+QAUDSTOP Stop Playing Media File

Stop the audio file playback triggered by AT+QAUDPLAY.

AT+QAUDSTOP Stop Playing Media File

Test Command AT+QAUDSTOP=?	Response OK
Execution Command AT+QAUDSTOP	Response OK
Reference	

Example

```

AT+QAUDRD=1,"A.amr",3 // Record a media file in AMR format, store it in UFS.
OK // Name it as "A"
AT+QAUDRD=0
OK // Stop the recording.
AT+QAUDRD=1,"SD:B.wav" // Record a media file in WAV_PCM16 format, store it in
OK SD root directory and Name it as "B".
AT+QAUDRD=0 // Stop the recording
OK
// Create a subdirectory named "picture" before recording
AT+QAUDRD=1,"SD:picture\C.wav" // Record a media file, and store it in SD subdirectory,
OK // Name it as "C".
    
```

```

AT+QAUDRD=0 //Stop the recording
OK
AT+QAUDPLAY="A.amr",0,100,1 // Play the "A" media file, not repeat, volume 100, through
OK // headset.
+QAUDPIND: 0,5 // After playing is finished, URC report is output
AT+QAUDPLAY="SD:picture\B.wav",0,100,1 // Play the "B" media file, not repeat, volume 100,
OK // through Headset.
+QAUDPIND: 0,5 //After playing is finished, URC report is output.
AT+QAUDPLAY="SD:C.wav",1,80,1 // Play the "C" media file, repeat, volume 80, through
OK // headset.
AT+QAUDSTOP // Stop the playing
OK
    
```

5.2.4. AT+QPLAYRES Play Audio Stream from Resource Bin

Play back the audio binary (.bin) that is already downloaded into flash in idle mode and output it to speakers.

AT+QPLAYRES Play Audio Stream from Resource Bin

Test Command AT+QPLAYRES=?	Response +QPLAYRES: "resname",(list of supported <repeat>s),(list of supported <volume>s) OK
Write Command AT+QPLAYRES="resname",<repeat>,<volume>	Response OK If error is related to ME functionality: +CME ERROR: <err>
Reference	

Parameter

"resname"	A string prefixed with "RES:", followed by the audio ID, like "RES:0001". The ID of the N th audio resource is N. For example, the first is 0001; the second is 0002 and so on.
<repeat>	Whether to play media file repeatedly 0 Play only once 1 Play repeatedly
<volume>	Volume level. Range: 0-100

NOTES

1. If the audio is not found in Bin file, error is returned.
2. Use the audio resource generator to make a bin. See appendix, chapter 8.

5.2.5. AT+QSTOPRES Manually Stop the Audio Resource Playing

Stop the audio bin playback triggered by AT+QPLAYRES.

AT+QSTOPRES Manually Stop the Audio Resource Playing

Test Command AT+ QSTOPRES=?	Response OK
Execute Command AT+ QSTOPRES	Response OK
Reference	

Example

```

AT+QAUDCH=1 // Set output channel to earphone
OK
AT+QPLAYRES="RES:0023",0,1 // Play the 23th audio for once
OK
+QAUDPIND: 0,0 // Playing completes
AT+QPLAYRES="RES:0023",1,1 // Play the 23th audio endlessly
OK
AT+QSTOPRES // Stop playing
OK
    
```

5.2.6. AT+QPRESBG Playback Audio from Resource Bin to the Remote in Call

Play back audio bin that is already downloaded into flash during voice call. The audio will be mixed to the uplink and downlink speech.

AT+QPRESBG Playback Audio from Resource Bin to the Remote in Call

Test Command AT+QPRESBG=?	Response +QPRESBG: (list of supported <control>s),[(list of supported <ID>s),(list of supported <ul_vol>s),(list of supported <dl_vol>s)[,(0-2)]]
	OK

Write Command AT+QPRESBG=<control>[,<ID>,<ul_v ol>,<dl_vol>[,<channel>]]	Response OK
Reference	

Parameter

<control>	Start playback or stop the playback 0 Stop playing. The parameters behind <mode> can be omitted 1 Play audio bin resource
<ID>	Sequence number of audio resource in bin file Range: 1-N (N: integer, total numbers of audio files)
<ul_vol>	Uplink volume Range: 0 - 7
<dl_vol>	Downlink volume Range: 0 - 7
<channel>	Audio output channel. It is optional. 0 Normal audio channel 1 Headset 2 Loud Speaker

NOTES

- URC Report: +QPRESBG: 0,<result>
<result>=5: playing finished
<result>=6: playing interrupted
- Audio resource can only be AMR file or 8KHz WAV file.
- If <channel> is not be set in this command, the channel will be controlled by AT+QAUDCH.

Example

```

AT+QPRESBG=?
+QPRESBG: (0,1),(1-n),(0-7),(0-7)[,(0-2)]

OK
AT+QPRESBG=1,1,6,7,1           // Play the audio which's sequence number is 1 in bin resource.
OK                               // Uplink volume is 6; downlink volume is 7, use earphone to play
AT+QPRESBG=0                   // Stop playback
OK
AT+QAUDCH=0                     // Set main channel to play audio
OK
AT+QPRESBG=1,2,6,5             // Play the audio which's sequence number is 2 in bin resource.
OK                               // Use main channel to play

```

5.2.7. AT+QPSND Play Audio File and Send it to the Remote in Call

Play back the audio files during voice call. The audio will be mixed to the uplink and downlink speech.

AT+QPSND Play Audio File and Send it to the Remote in Call

Test Command AT+QPSND=?	Response +QPSND: (list of supported <control>s),"filename",(list of supported <repeat_cnts>s),(list of supported <ul_vol>s)[,(list of supported <dl_vol>s)][,(list of supported <channel>s)] OK
Write Command AT+QPSND =<control>[,"filename",<repeat_cnts> ,<ul_vol>[,<dl_vol>[,<channel>]]]	Response OK If error is related to ME functionality +CME ERROR: <err>
Reference	

Parameter

<control>	Start playback or stop the playback 0 Stop the playback 1 Start playback
"filename"	File name of the audio file. If file is located in UFS, embrace the file name into the quotes, e.g. "example.wav"; If file is located in SD card, add label "SD:" ahead of the file name, e.g. "SD:example.wav". The audio file must be 8KHz wav file or AMR file.
<repeat_cnts>	Repeat counts 0 Repeat endless N Repeat N times, Range of N:1-32767
<ul_vol>	Uplink volume Range: 0 - 7
<dl_vol>	Downlink volume Range: 0 - 7
<channel>	Audio output channel of playback 0 Normal audio channel 1 Headset 2 Loudspeaker

NOTES

1. If playback during voice call, the <channel> will not take effect, instead, the downlink sound will output from the same speaker with speech. If playback without voice call established, the <channel> will take effect.
2. If this parameter is omitted, the output path will be decided by AT+QAUDCH.
3. The audio file must be 8KHz WAV file or AMR file, otherwise, the playback will fail

Example

```

AT+QPSND=? // Query parameter
+QPSND: (0,1),"filename",(0-32767),(0-7)[,(0-7)][,(0-2)]

OK
AT+QPSND=1,"rec01.wav",1,7,7 // Start playback
OK
AT+QPSND=0 // Stop the playback
OK
    
```

5.2.8. AT+QPCMD Play PCM Stream from UART to the Remote in Call

Play back PCM stream that is input from UART during voice call. The audio will be mixed to the uplink and downlink speech.

AT+QPCMD Play PCM Stream from UART to the Remote in Call

Test Command AT+QPCMD=?	Response +QPCMD: (list of supported <control>s)[,(list of supported <ul_vol>s),(list of supported <dl_vol>s),(list of supported <format>s)[,(list of supported <uart>s)]] OK
Write Command AT+QPCMD=<control> [,<ul_vol>,<dl_vol>,<format>[,<uart>]]	Response if <uart> is AT command port, response OK CONNECT else response OK If error is related to ME functionality +CME ERROR: <err>
Reference	

Parameter

<control>	Start playback or stop the playback 1 Start play PCM stream 0 Stop play PCM stream
<ul_vol>	Uplink volume Range: 0-7
<dl_vol>	Downlink volume Range: 0-7
<control>	Format of PCM stream 0 16-bit linear PCM 1 8-bit linear PCM 2 8-bit a-law 3 8-bit u-law
<uart>	UART port number of PCM stream to input. The default port is AT command port. Range: 1-3

NOTES

1. If <control> is 0, other parameters are ignored.
2. The format of PCM stream must be PCM raw data and the sample rate must be 8k HZ.
3. Recommend to set <dl_vol> to 0
4. Recommend to open hardware flow control
5. On <uart> port,
If buffer of UART is full, the following URC will be reported,
FULL
If buffer of UART resumes empty, the following URC will be reported,
READY

Example

```

AT+QPCMD=1,7,0,2 // Start to play PCM input from the AT command port
OK

CONNECT // Enter data mode

READY // UART is ready to receive PCM data.
<Then send PCM stream to UART>
FULL // UART buffer is full, recommended to stop send PCM data.

READY // UART is ready to receive PCM data.
+++ // Input “+++”to exit data mode and stop play PCM.
OK
AT+QPCMD=1,7,0,2 // Start to play PCM data which is input from a different serial port from AT

```

```
command port
OK
<Send PCM stream to UART2>
AT+QPCMD=0           // Stop playing PCM.
OK
```

5.2.9. AT+QMEDVL Set/Get Media Volume Gain

Get or set the volume level of media playback in idle mode. This command controls the volume level of AT+QAUDPLAY and AT+QTTS. Volume gain of uplink/downlink of AT+QPSND, AT+QPRESBG and AT+QPCMD cannot be controlled by this command.

AT+QMEDVL Set/Get Media Volume Gain

Test Command AT+QMEDVL=?	Response +QMEDVL: (list of supported <volume>s) OK
Read Command AT+ QMEDVL?	Response +QMEDVL: <volume> OK
Write Command AT+QMEDVL=<volume>	Response OK If format is error, response +CME ERROR: <err>
Reference	

Parameter

<volume> Volume level of media playback
Range : 0-100

Example

```
AT+QMEDVL=?           // Test command
+QMEDVL: (0-100)

OK
AT+QMEDVL?           // Read command
+QMEDVL: 50

OK
AT+QMEDVL=90         // Write command
OK
```

6 Appendix A Reference

Table 7: Related Documents

SN	Document name	Remark
[1]	Mxx_AT_Commands_Manual	AT Commands Manual

Table 8: Terms and Abbreviations

Abbreviation	Description
ME	Mobile Equipment
TA	Terminal Adapter
MS	Mobile Station
UFS	User File Storage
NV	Non-volatile

7 Appendix B Error Codes

Table 9: Description of Different Coding Schemes

Code of <err>	Meaning
4300	Wrong format
4302	Audio task busy
4303	Create file failed
4304	Additional recording in a different format
4305	Disc full
4306	File write protect
4401	Play PCM fail
4402	Audio device busy
4403	No memory
4404	UART buffer full

8 Appendix C Audio Resource Generator

This chapter introduces how to generate the audio resource bin. The PC side tool is provided.

8.1. Overview

Audio stream data in wav and AMR files could be packed into a binary file (.bin) with Quectel tool **GenBinFile**. Such .bin file could be downloaded into module just like the firmware upgrade, and can be played back with the AT+QPLAYRES and AT+QPBGRES.

8.1.1. Advantages

There are three advantages of using audio bin to play audio:

- Do not occupy the space of file system.
- Audio Data can be saved to module conveniently
- It is able to play AMR file or wave file to the other side during the voice call

8.1.2. Procedure

The whole procedure of Audio Bin includes four steps:

Step1: Prepare audio resource. It supports the format of AMR and wav only now.

Step2: Use the tool of **GenBinFile** to pack the audio resource to a bin file

Step3: Use the tool of Firmware_Upgrade_Tool_Lite_GS2_V1.2 to download the bin file to the module

Step4: Use AT commands to play audio.

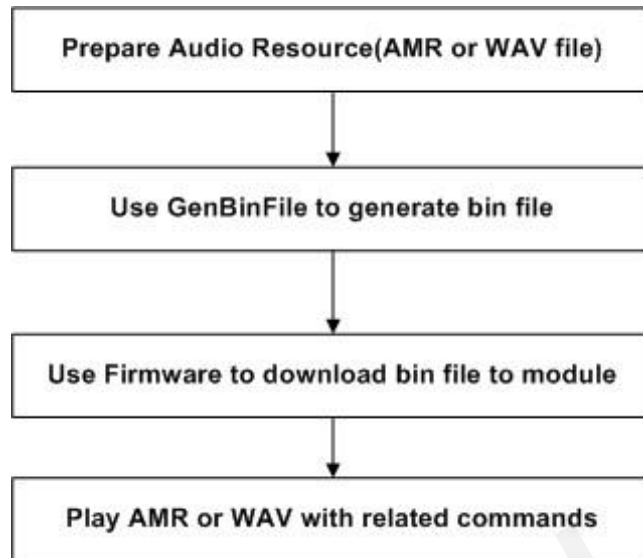

Figure 2: Procedure

The figure above shows that it is needed to make audio bin file and download it to module before playing audio. Next chapters will describe the method for making and downloading bin file.

8.2. Make and Download Bin File

8.2.1. Make Bin File

8.2.1.1. Prepare Audio Resource

Audio bin file is made from audio resource file. The format of audio file which is used to make bin file must be AMR or WAV. And the tool of GenBinFile only supports the two formats. When audio resource is ready, it must be put into the folder of “audio” at the same directory of GenBinFile tool. Refer to figure below.

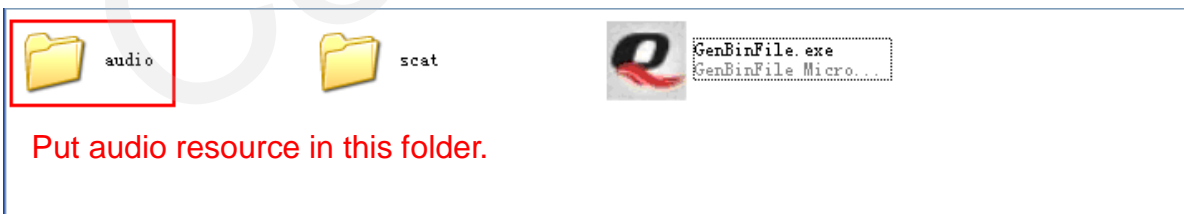

Figure 3: Prepare Audio Resource File

8.2.1.2. Run GenBinFile

Double-click the icon of GenBinFile and open the interface of this tool. Refer to the figure below.

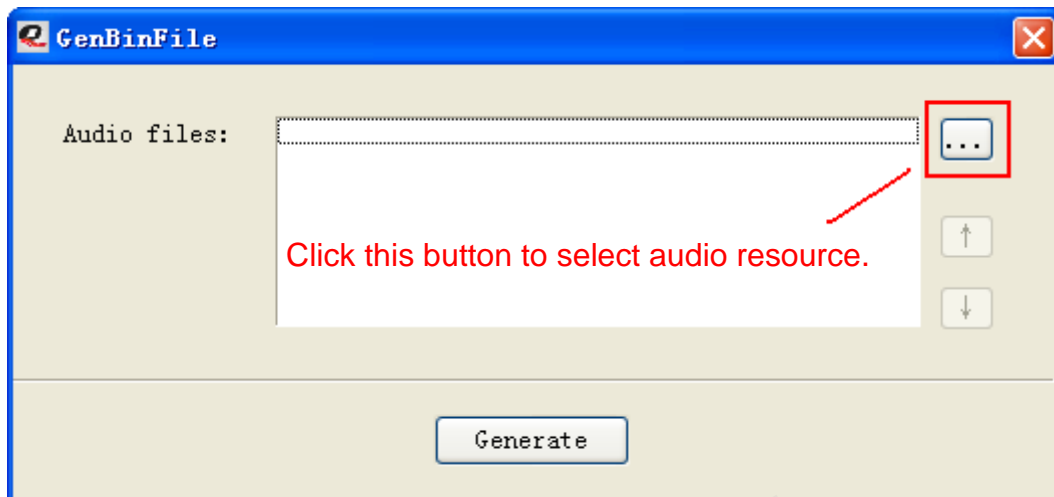

Figure 4: Interface of GenBinFile

8.2.1.3. Select Audio Resource

Click the “...” button and the dialog box window for choosing audio resource will be displayed. The default directory showed in this window is the location of GenBinFile tool. Open “audio” folder and select one or more audio resource in the interface of dialog window. Refer to the figures below.

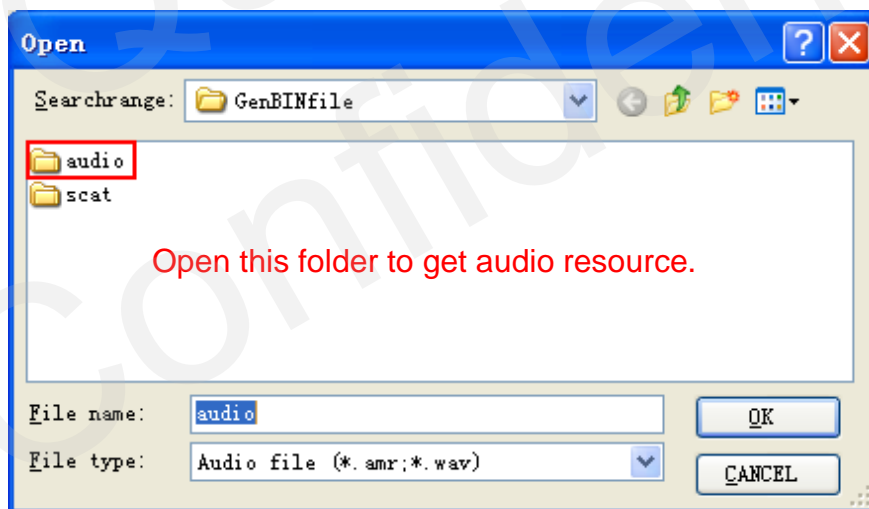

Figure 5: Open the “Audio” Folder

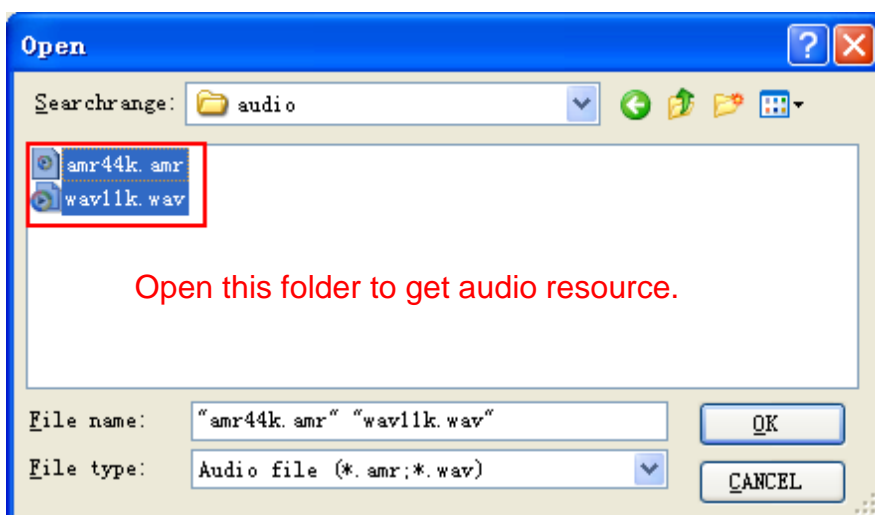

Figure 6: Select One or More Audio Resource

8.2.1.4. Change the Order of Audio Resource

Click “OK” button on the figure above. The tool will be back to the main interface. The audio resources are listed in the box. The audio resource has ranged automatically in an order in this list. The order of audio resource can be changed by clicking “↑” or “↓” button on the right side of tool. Refer to the figure below.

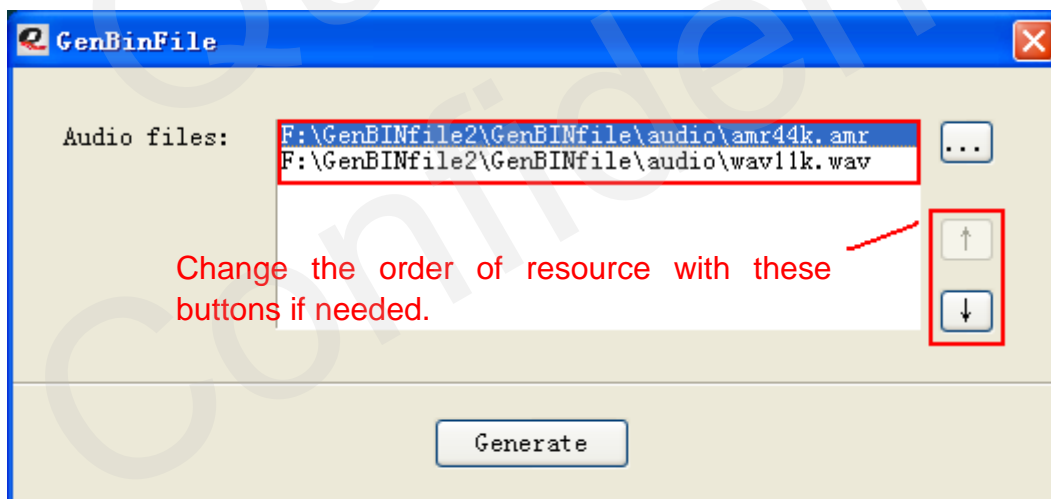

Figure 7: Change the Order of Resource

8.2.1.5. Generate the Bin and Scatter file

When the order of audio resource is fixed, it begins to generate the audio bin and scatter file. Just click the “Generate” button on the figure above and the result of generating will be showed in a prompting frame. Refer to the figure below.

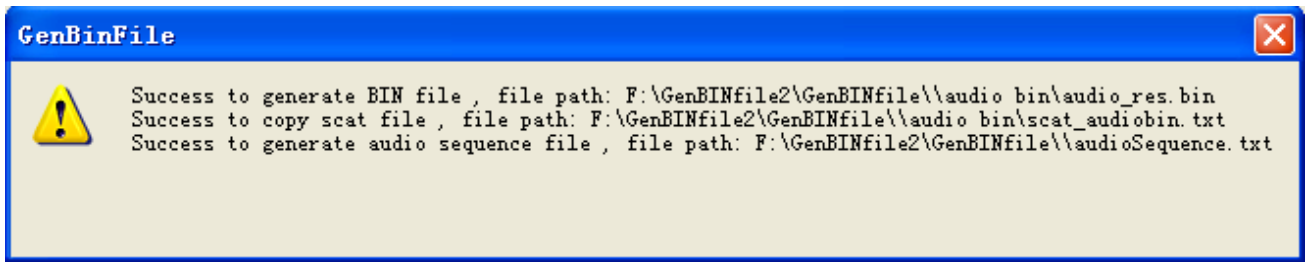

Figure 8: Prompt of Generating

The prompting frame shows the path of file which has generated successfully. It is going to have two files to be generated: audio_res.bin which is the bin file used to be played and audioSequence.txt which just shows the order of audio resource packed into bin file.

After the step of generating, audio bin file has been generated. The bin file is saved in the default folder at the same directory of GenBinFile tool. Refer to the figure below.

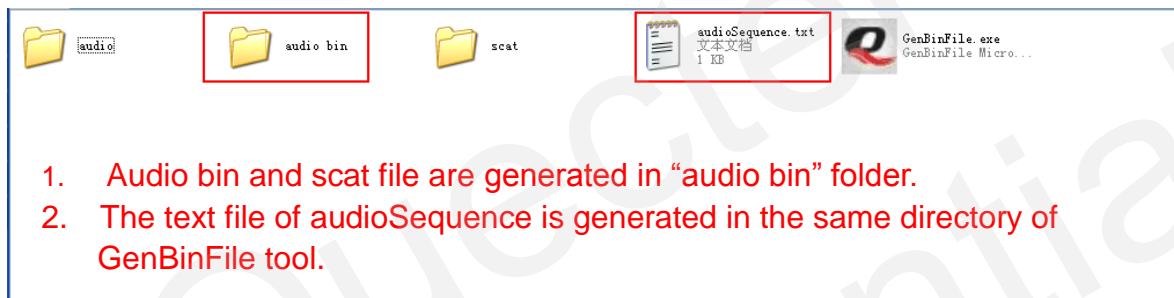

Figure 9: Generate the Audio Bin and Sequence File

Next, it is just needed to download it to the module and play.

8.2.2. Download Audio Bin File to Module

1. Connect the module and PC.
2. Open the tool of Firmware_Upgrade_Tool_Lite_GS2_V1.2. Configure the tool. Refer to the figure below.

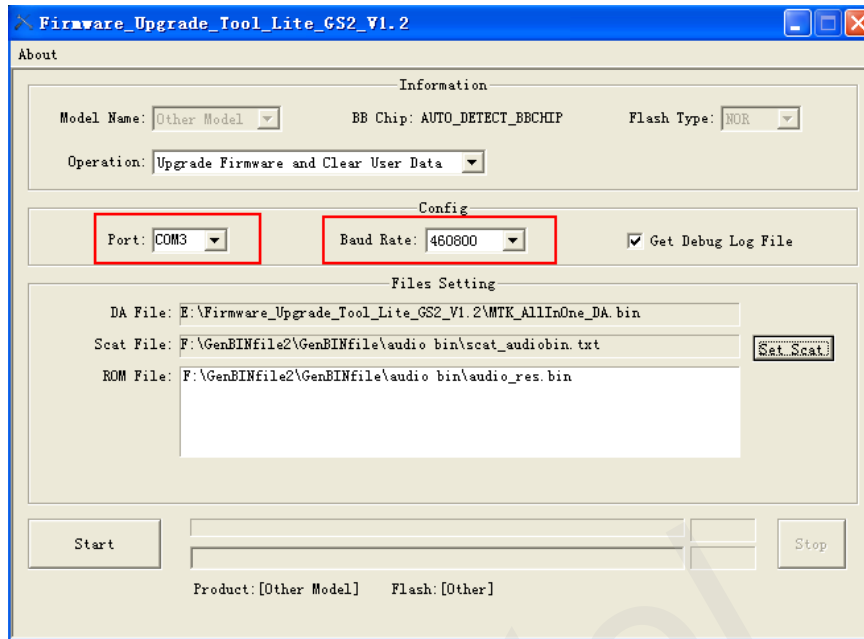

Figure 10: Configure the Firmware

3. Select the port which is used to connect with module and select 460800 for the Baud Rate.
4. Click “Set Scat” button on the figure above to select the scat file to load the bin file. Scat file is in the same path of bin file. Refer to the figure below.

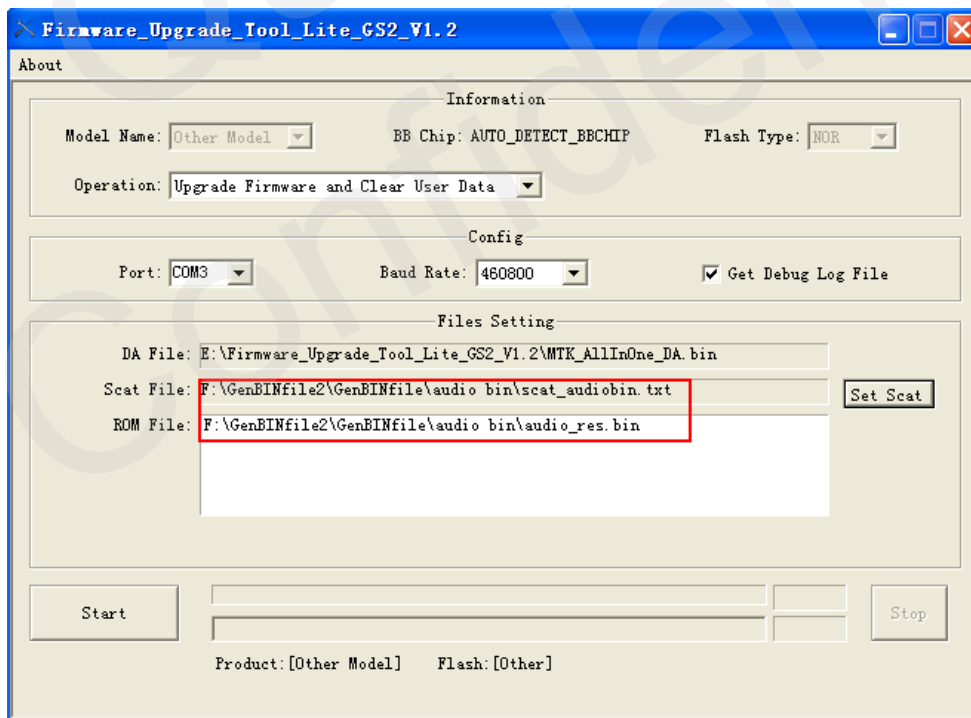

Figure 11: Select the Scat File

- After confirming the scat and audio bin file correctly, click “start” button and power on the module. The firmware will show the progress bar as the figure below.

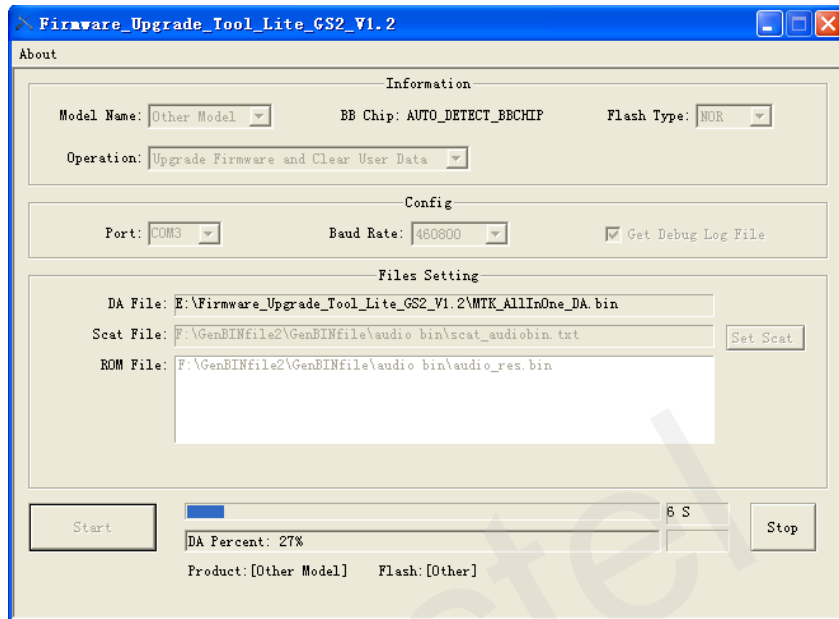

Figure 12: Start to Download

- If it is successful to accomplish the downloading, the firmware will prompt as the figure below.

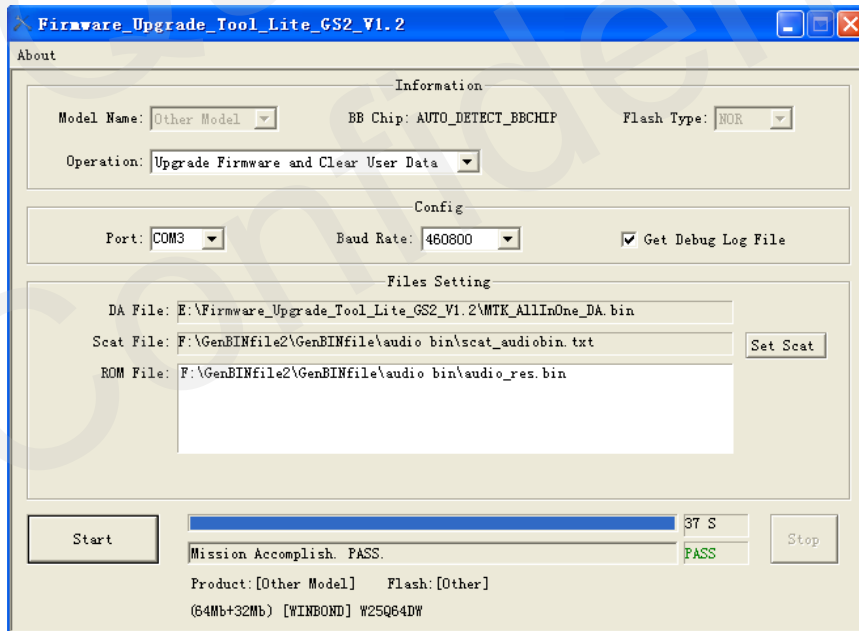

Figure 13: Finish Downloading

The figure above shows that it is successful to accomplish the downloading of audio bin file. And then, close the Firmware tool and reboot module. It is able to play audio with AT commands now.